

(12) PATENT APPLICATION PUBLICATION	(21) Application No. : 61/MUMNP/2006	A
(19) INDIA	(43) Publication Date: 06/10/2006	
(22) Date of filing of Application: 17/01/2006		

(54) Title of the invention: METHOD OF CHARGING FINE-GRAINED METALS INTO AN ELECTRIC-ARC FURNACE

(51) International classification : C21C 5/52  
(31) Priority Document No : 103 33 764,4-24  
(32) Priority Date : 23/07/2003  
(33) Name of priority country : GERMANY  
(86) International Application No : and  
Filing Date : PCT/EP2004/007153  
01/07/2004  
(87) International Publication No : WO 2005/014868  
(61) Patent of addition to  
Application No : NIL  
Filed on : N.A.  
(62) Divisional to Application No : NIL  
Filed on : N.A.

(71) Name of Applicant:  
1. OUTOKUMPU TECHNOLOGY OY  
2. SMS DEMAG AG  
Address of the Applicant:  
1. RIIHITONTUNTIE 7,  
FIN-02200 ESPOO, FINLAND  
2. EDUARD-SCHLOEMANN-  
STRASSE 4, 40237  
DUSSELDORF, GERMANY

(72) Name of the Inventor:  
1. EICHBERGER HEINZ  
2. SCHNEIDER KARL-JOSEF

(57) Abstract: In a method of charging fine-grained metals, in particular directly reduced iron (DRI), into an electric-arc furnace (1), the metal is supplied via a downpipe (12) to an opening (10) provided in the furnace roof (4), is introduced into the furnace (1) through this opening (10) as bulk material stream (11), and falls onto the melt (13) merely by gravity. Further, an electric-arc furnace (1) suited for this purpose is described. A rather loss-free introduction even of fine-grained material having a mean grain size of less than 1 mm is achieved by passing the bulk material stream (11) through a dosing orifice (8) after the downpipe (12) and before entering the furnace (1). The bulk material stream (11) then enters the furnace essentially undisturbed.

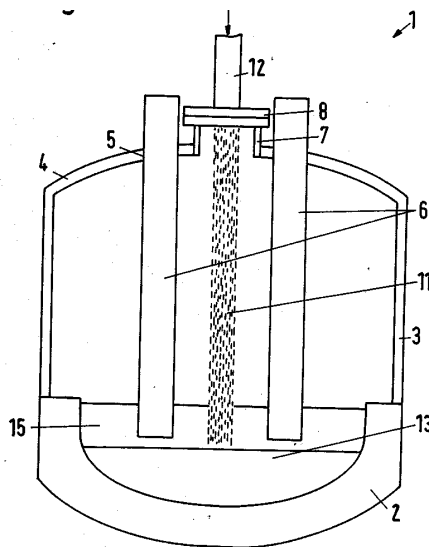

Fig. 1

Drawing: 3 Sheets  
Total Pages: 18